

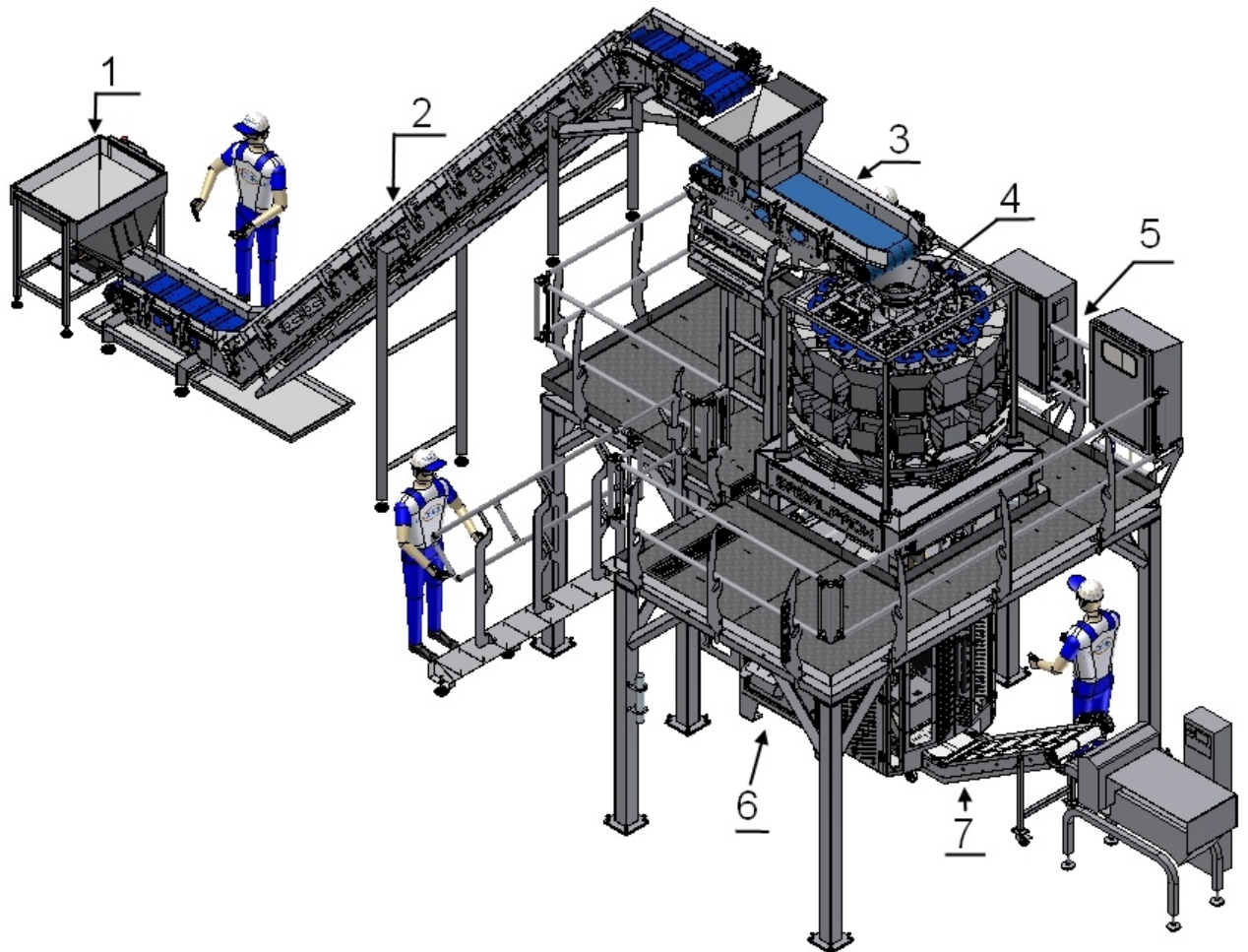

SABALPACK

ARCTIC SERIES



- 1:** LOADING VIBRATING HOPPER 200Lt
- 2:** MAIN FEEDING CONVEYOR WITH MODULAR BELT
- 3:** FEEDING CONVEYOR FOR MULTIHEAD WITH MODULAR BELT
- 4:** MTS01 - ARCTIC 14T 8Lt
- 5:** STAINLESS STEEL SUPPORT STRUCTURE WITH STAIRS AND BALCONY WITH STAINLESS STEEL FLOOR
- 6:** VERTICAL PACKAGING MACHINE MOD. LEOPARD
- 7:** TAKE AWAY CONVEYOR

1: LOADING VIBRATING HOPPER 200Lt

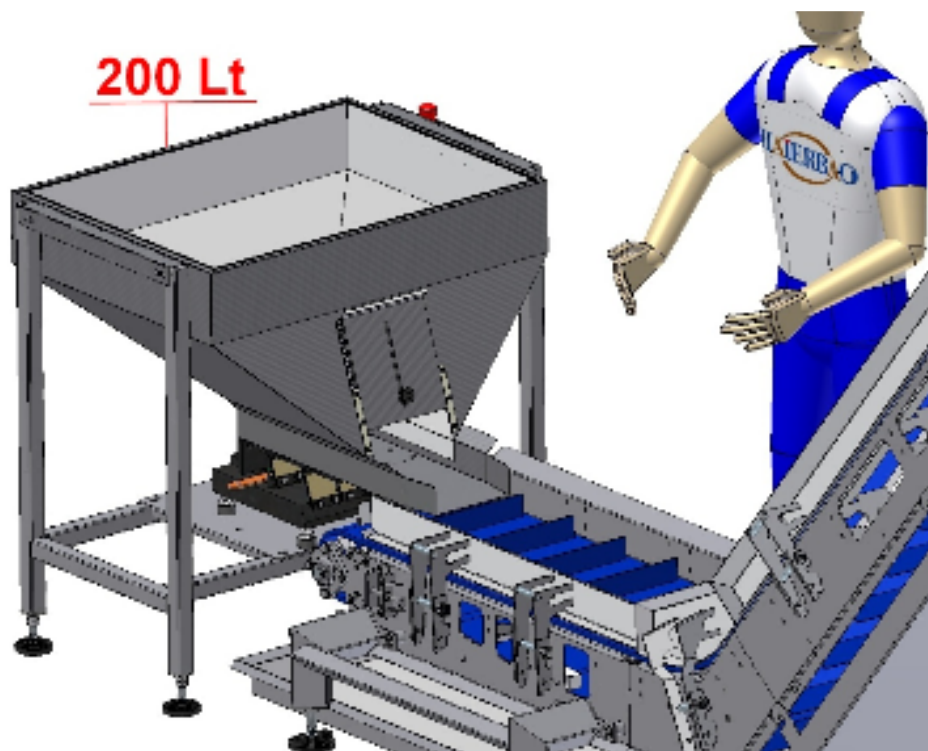

2: MAIN FEEDING CONVEYOR WITH MODULAR BELT

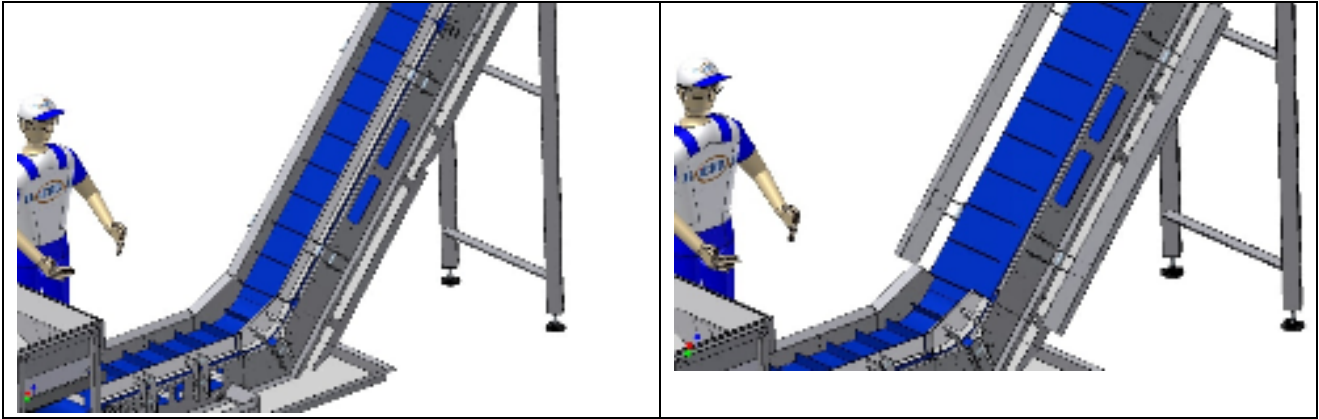

3: FEEDING CONVEYOR FOR MULTIHEAD WITH MODULAR BELT

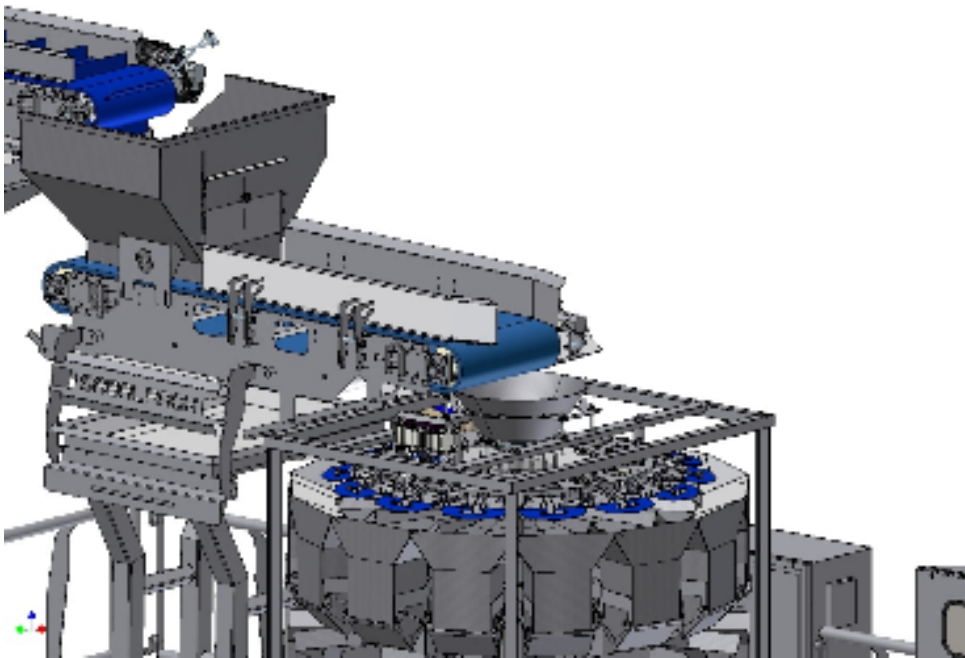

4: MTS01 - ARCTIC 14T 8Lt COMPUTER CONTROLLED COMBINATION WEIGHER
100% MADE IN ITALY

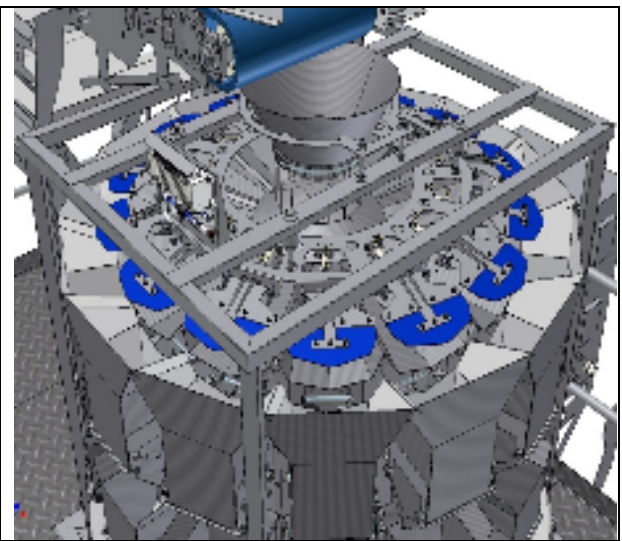
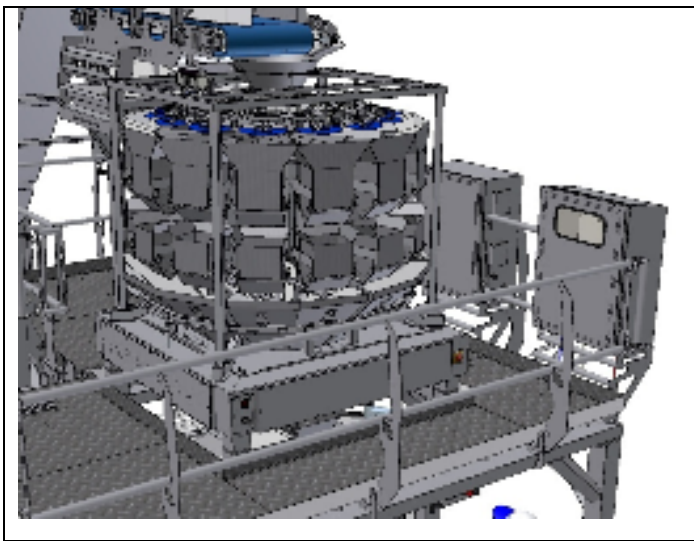

5: STAINLESS STEEL SUPPORT STRUCTURE WITH STAIRS AND BALCONY WITH STAINLESS STEEL FLOOR

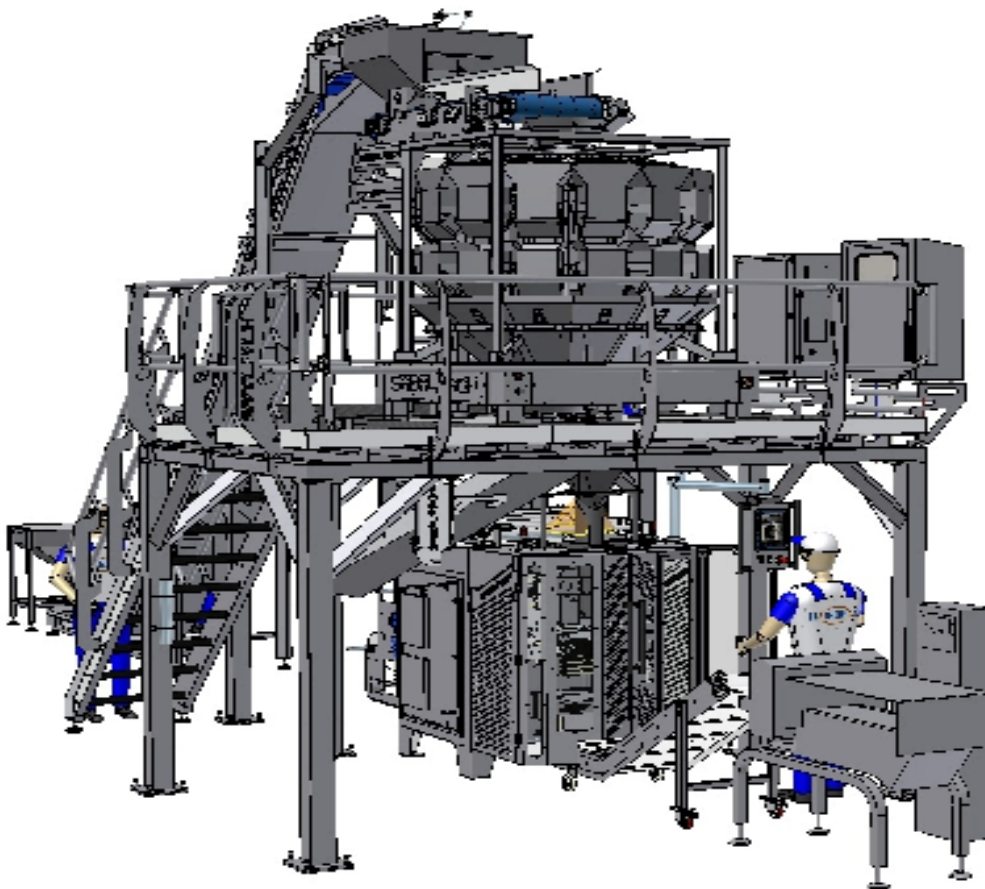

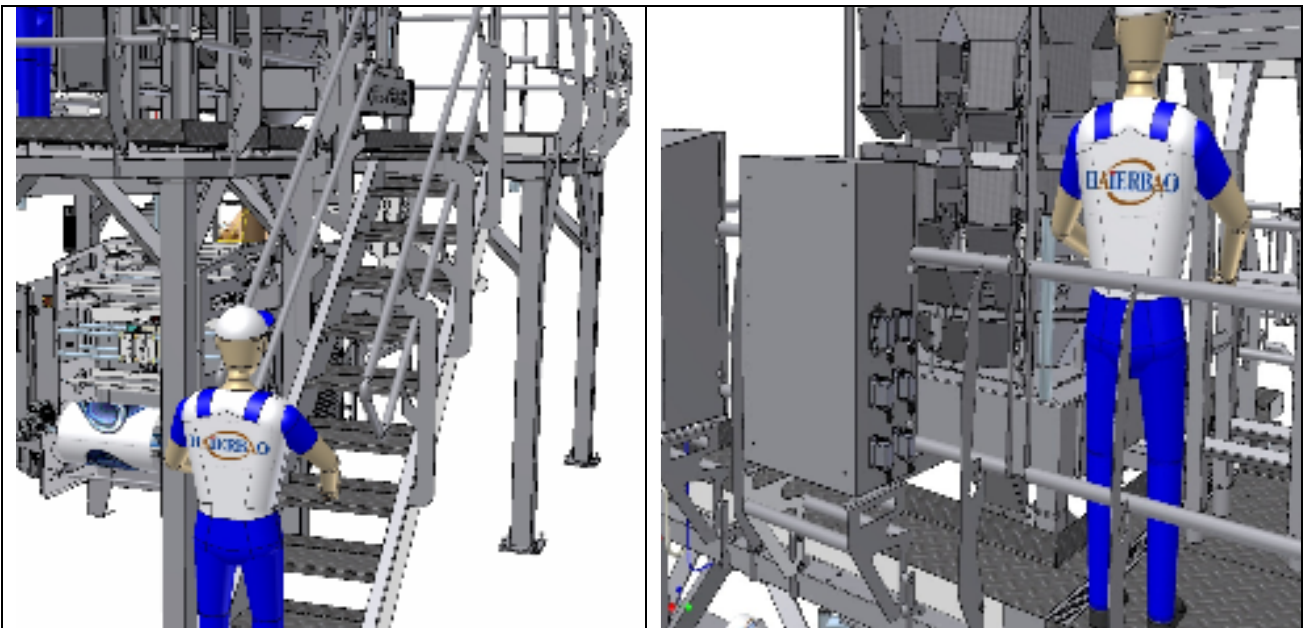

6: VERTICAL PACKAGING MACHINE MOD. LEOPARD ARCTIC 100% MADE IN ITALY

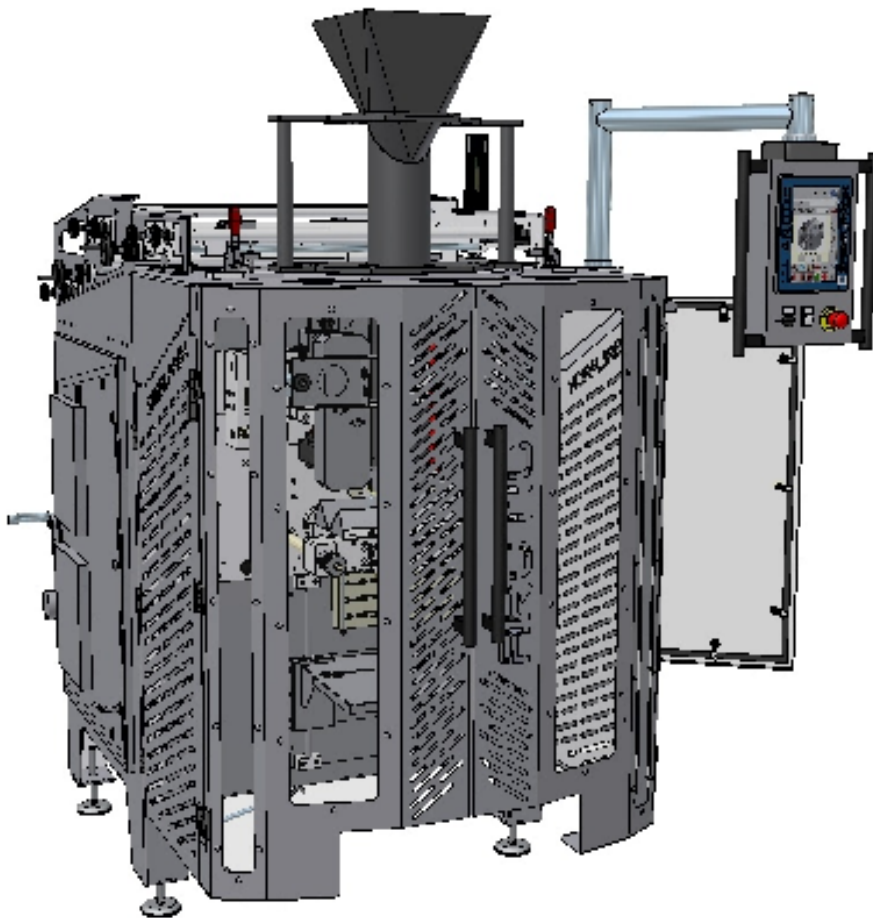

SIEMENS PLC S7-300:

capitolato_03/011



TOUCH SCREEN 10.4":

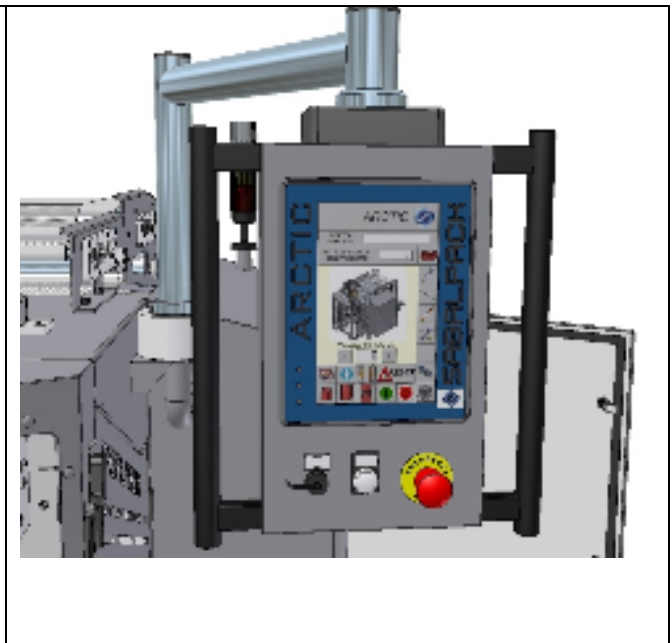

HORIZONTAL SEALING BAR STARTED BY A BRUSHLESS ELECTRONIC MOTOR:

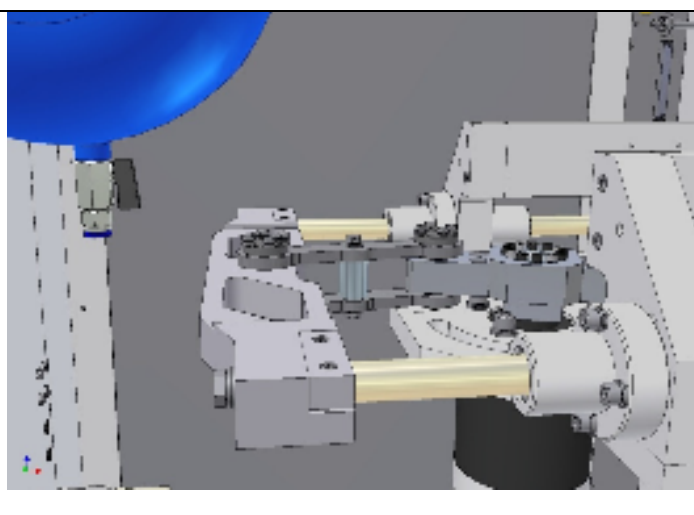
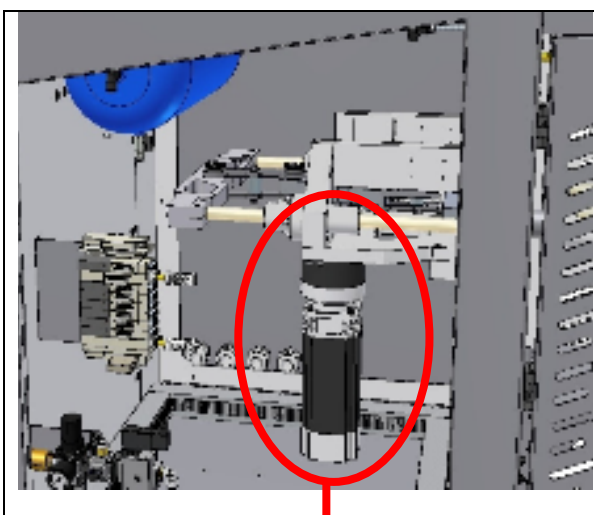
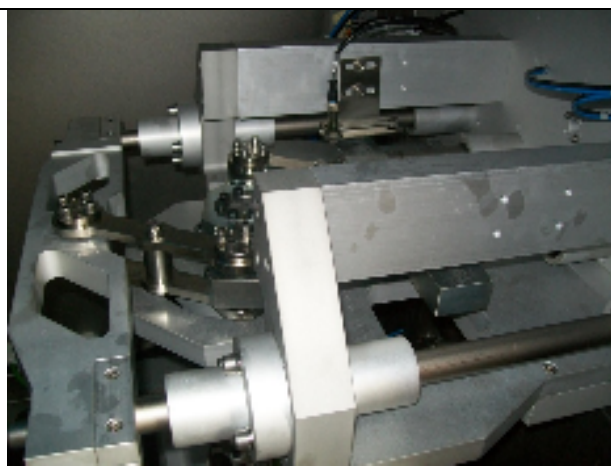
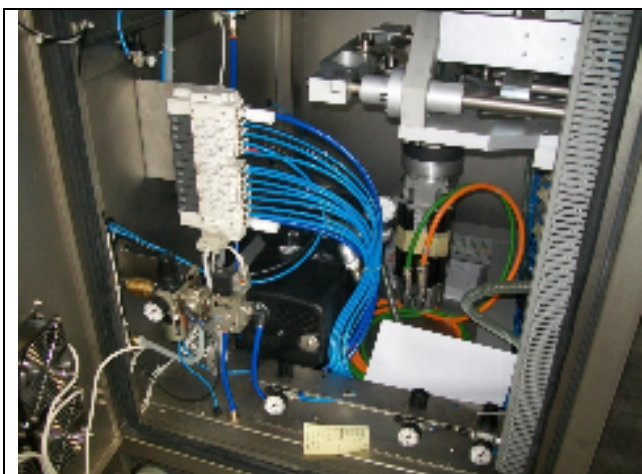

**Motore Brushless 9,4 Nm - 3000rpm 5V line diver.l
Azionamento DIGITAX PLUS 5,9A 17,7A 380/480V 3ph**

FILM DRAGGING SYSTEM EQUIPPED WITH ELECTRONIC STEP-BY-STEP MOTOR

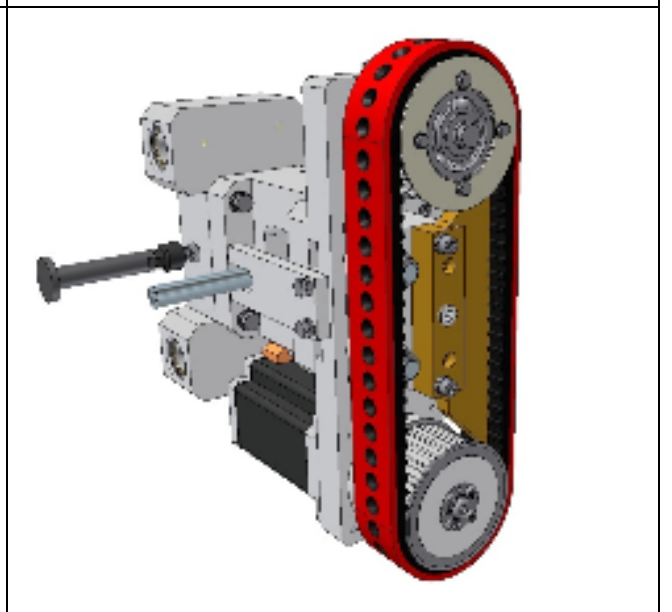
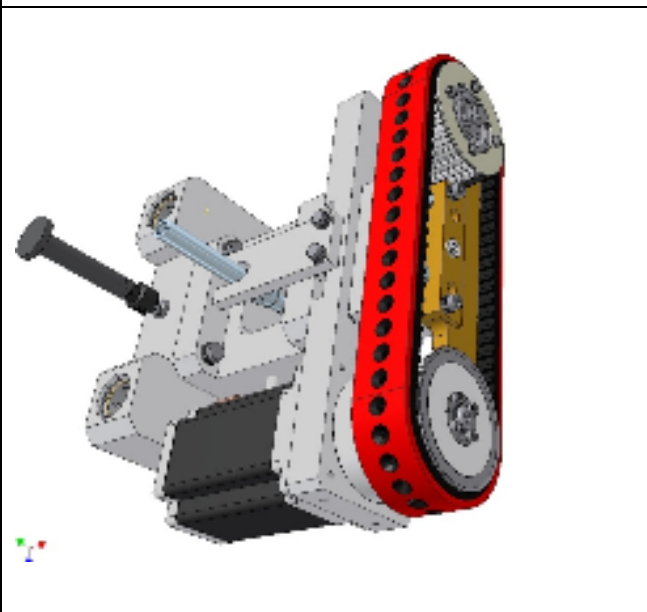
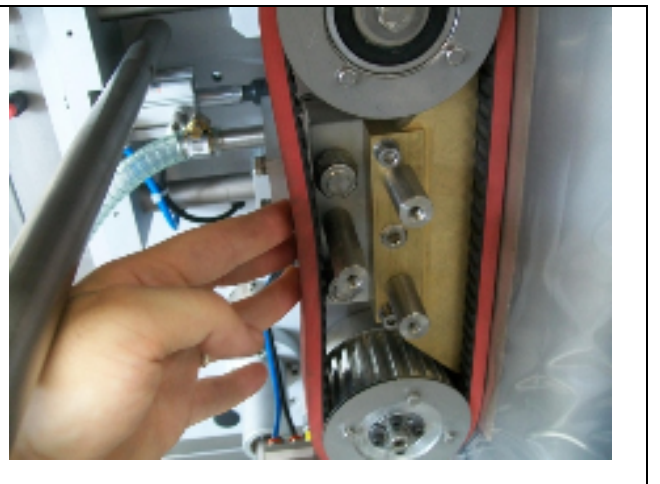
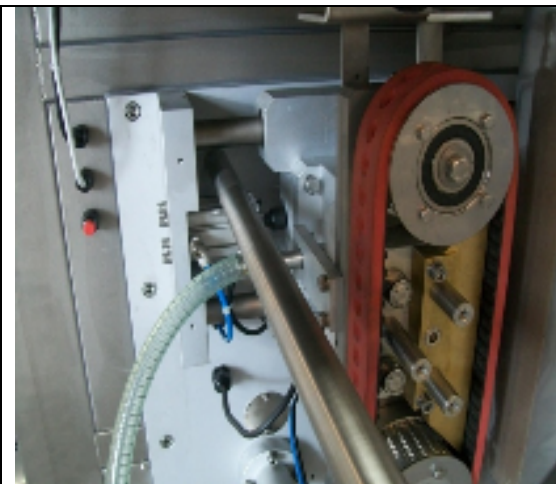
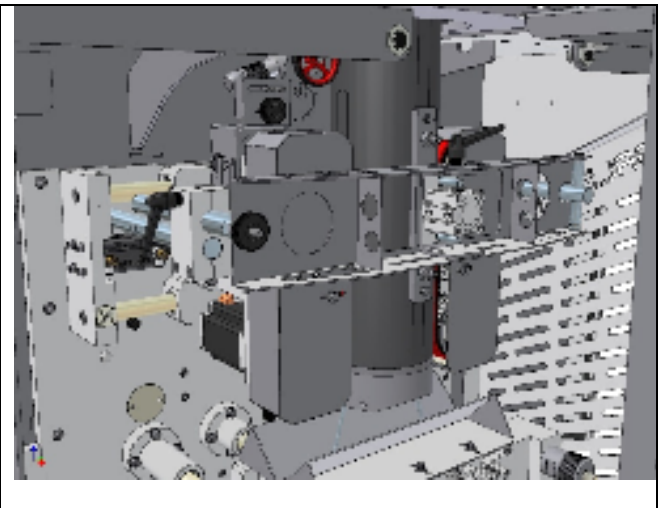

SEALING SYSTEM FOR PE FILM BY ROPEX

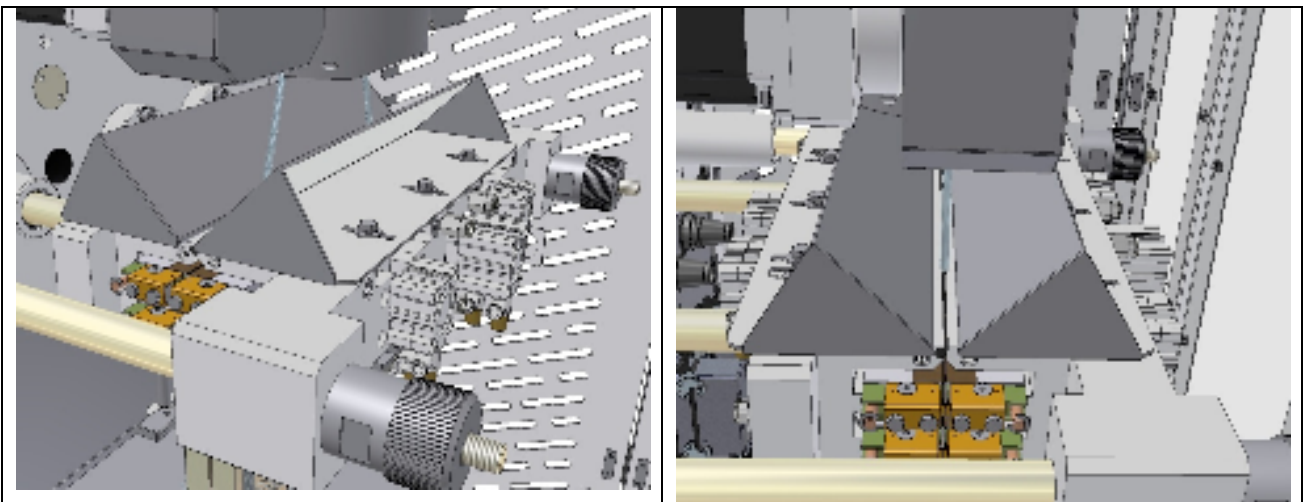

VIDEOJET DataFlex Plus 53mm (Printing area 53 mm. x 75 mm)

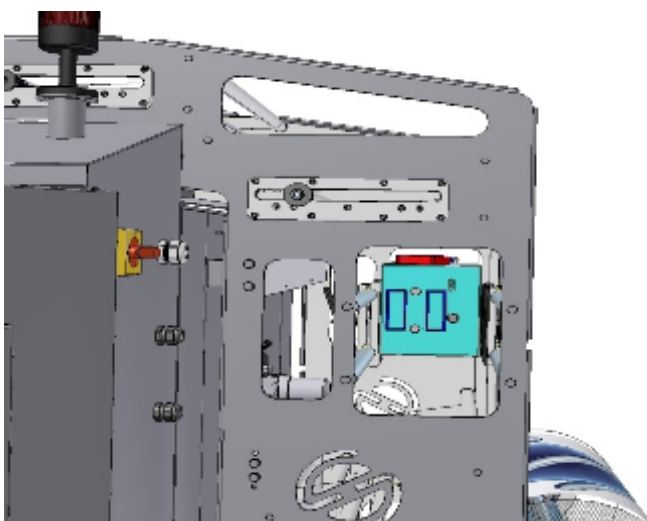

PILLOW BAG FORMING TUBE

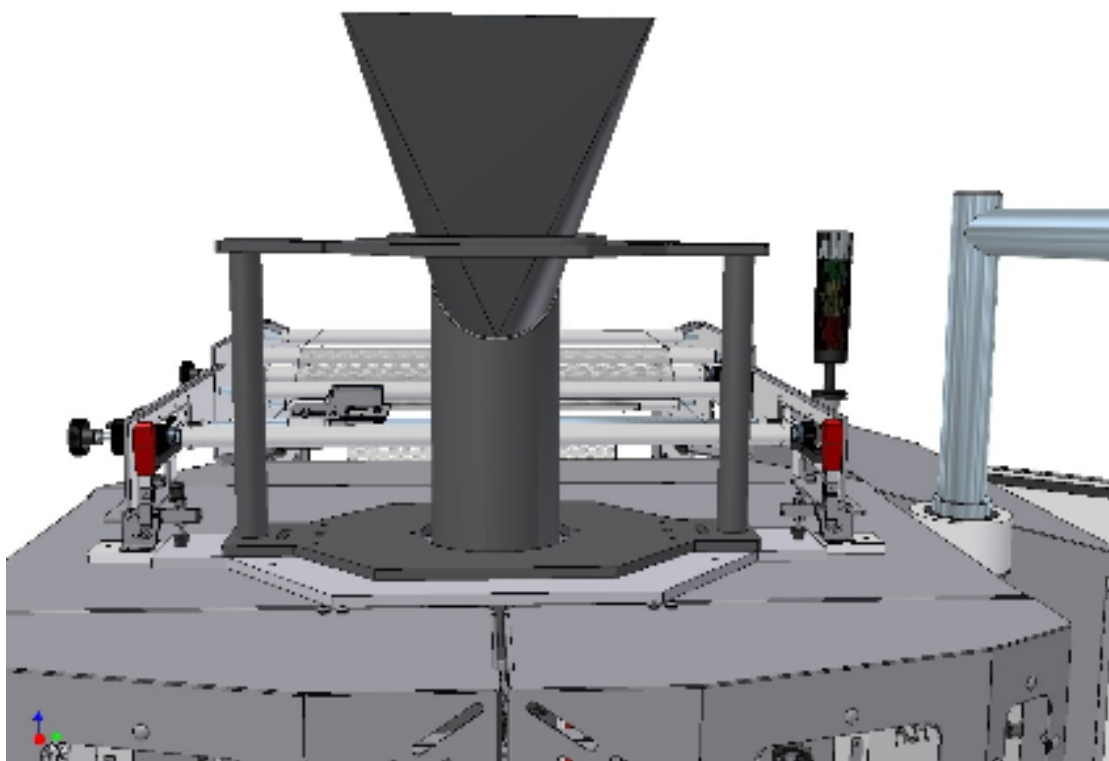

7: TAKE AWAY CONVEYOR

